



# Inductive sensor

## NJ60-FP-A2-P1-Y237070

- 60 mm non-flush
- Detects stainless steel tubes in bottles
- Steam resistant
- 2. oscillator frequency



### Dimensions

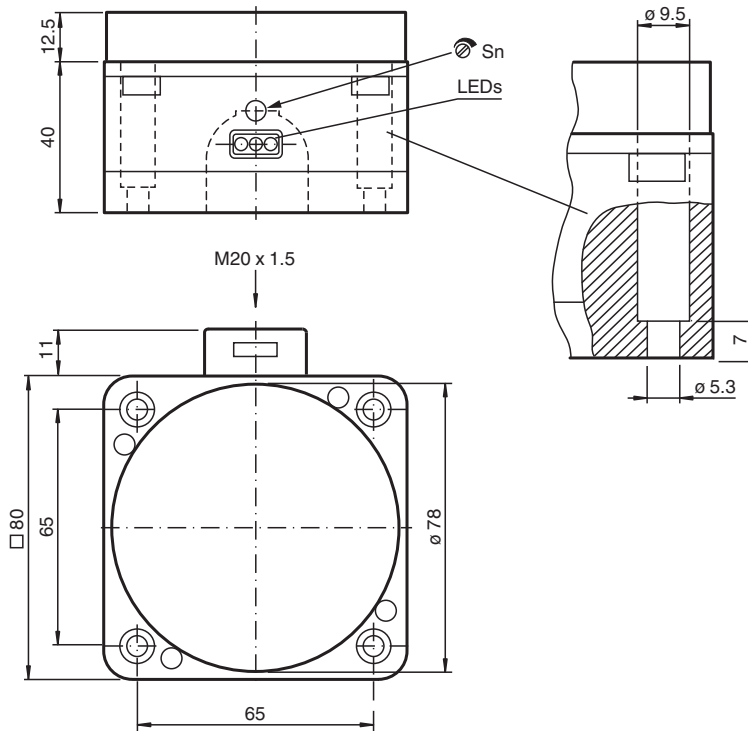

### Technical Data

#### General specifications

Switching function		complementary
Output type		PNP
Rated operating distance	$s_n$	60 mm
Installation		non-flush
Output polarity		DC
Assured operating distance	$s_a$	0 ... 50 mm
Measuring body		high grade steel tube
Reduction factor $r_{Al}$		0.4
Reduction factor $r_{Cu}$		0.3

Release date: 2024-05-28 Date of issue: 2024-06-02 Filename: 237070\_eng.pdf

Refer to "General Notes Relating to Pepperl+Fuchs Product Information".

Pepperl+Fuchs Group  
www.pepperl-fuchs.com

USA: +1 330 486 0001  
fa-info@us.pepperl-fuchs.com

Germany: +49 621 776 1111  
fa-info@de.pepperl-fuchs.com

Singapore: +65 6779 9091  
fa-info@sg.pepperl-fuchs.com

**PF** PEPPERL+FUCHS

## Technical Data

Reduction factor $r_{304}$		0.85
Bottle speed		ca. 2.5 m/s (65000 btls./h)
Output type		4-wire
Adjustment aid		LED, green/red
<b>Nominal ratings</b>		
Operating voltage	$U_B$	10 ... 30 V
Switching frequency	$f$	0 ... 100 Hz
Hysteresis	$H$	typ. 3 %
Pulse extension		100 ms
Reverse polarity protection		reverse polarity protected
Short-circuit protection		pulsing
Voltage drop	$U_d$	$\leq 3$ V
Operating current	$I_L$	0 ... 200 mA
No-load supply current	$I_0$	$\leq 20$ mA
Time delay before availability	$t_v$	$\leq 20$ ms
Operating voltage indicator		LED, green
Switching state indicator		LED, yellow
<b>Compliance with standards and directives</b>		
Standard conformity		
Standards		EN IEC 60947-5-2
<b>Approvals and certificates</b>		
UL approval		cULus Listed, General Purpose
<b>Ambient conditions</b>		
Ambient temperature		0 ... 60 °C (32 ... 140 °F)
<b>Mechanical specifications</b>		
Connection type		screw terminals
Information for connection		A maximum of two conductors with the same core cross section may be mounted on one terminal connection! tightening torque 1.2 Nm + 10 %
Core cross section		up to 2.5 mm <sup>2</sup>
Minimum core cross-section		without wire end ferrules 0.5 mm <sup>2</sup> , with connector sleeves 0.34 mm <sup>2</sup>
Maximum core cross-section		without wire end ferrules 2.5 mm <sup>2</sup> , with connector sleeves 1.5 mm <sup>2</sup>
Housing material		POM
Sensing face		POM
Degree of protection		IP68
<b>Dimensions</b>		
Height		40 mm
Width		80 mm
Length		80 mm

## Connection

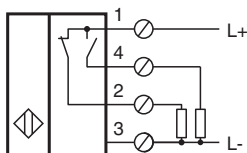

**Mounting**

**Installation**

The sensor should be mounted at least 30 mm above the conveyor chain. This ensures, that the sensor will not be influenced by the conveyor chain.

**Adjustment:**

For correct operation, the sensor has to be adjusted according to the application. The adjustment has to be carried out without the object, which has to be detected.

- 1) Supply the sensor (10 ... 30 V DC).  
leuchtet die grüne LED.
- 2) If the output is activated, the yellow LED is on
- 3) The adjustment is made without measuring body

The double LED in the middle has to light up green. If it doesn't, turn the sensitivity adjuster clockwise until the LED lights up yellow. Now turn the sensitivity adjuster counterclockwise until the double LED lights up green.

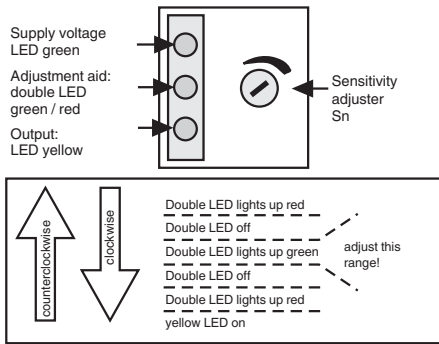

**Function check:**

To check the correct adjustment, test the reliable detection of a stainless steel test tube in the bottle.

Release date: 2024-05-28 Date of issue: 2024-06-02 Filename: 237070\_eng.pdf